

Introduction



Tough Cables that Keep Performing.

High performance cabling solutions have changed the face of modern production facilities, manufacturing processes and the industrial infrastructure. Today, industry depends on reliability and demands long life, superb performance, often in the toughest of environments – in practice, that means peace of mind to get on with the job.

Key applications

- Programmable logic controllers
- Human machine interfaces
- Remote I/O
- 4-20 mA systems (PLTC & TC instrumentation)

IndustrialTuff™

This is the world's most comprehensive line of industrial cabling solutions – whether for networking factory floor equipment, hardware and controllers or relaying data between the control room, the engineering department and remote manufacturing sites or a combination of all the above. Belden industrial cables are designed to provide reliable communication between corporate headquarters and the plant, management and employees and everywhere in between.

Industrial Solutions

• Industrial Ethernet: Networking Cables with Installable Performance™

The reliability of an industrial ethernet network fully depends on the cable infrastructure. Transmission errors can result in lost production time – and even downtime or safety issues. Belden understands the critical nature and demands of each industry and has designed its industrial ethernet cables to provide top performance for different, often very demanding, industrial applications.

Belden's patented bonded-pair cable constructions are included in the range of industrial ethernet products. Bonded-pair technology means installable performance – where cables are designed to withstand the pulling, bending, kinking, coiling and crushing that routinely takes place during installation.

• Industrial Data Solutions®

Belden's full range of Industrial Data Solutions® includes cables for all types of bus applications such as Profibus, Fieldbus, DeviceNet™, ControlNet™, InterBus-S®.

Belden practically invented Blue Hose® twinax cables from the original IBM specification; today these are the dominant call-out for PLC and DCS applications.

ControlBus quad shielded coax cables are for ControlNet™ applications – all Belden industrial coax cables provide the dependability for long-lasting performance. Also available is a full range of cables for Profibus and Fieldbus applications, as well as DeviceBus cables for ODVA DeviceNet™ systems.

In addition, Belden offers a wide range of Variable Frequency Drive (VFD) cables, Control and Instrumentation cables and the Infinity® line of flexible automation cables.

• Diverse Manufacturing Facilities

Belden cables can have many different characteristics to meet the requirements of different industrial cabling applications. The cables are resistant to:

- Effects of temperature
- UV sunlight
- Oils
- Gasoline
- Other chemical solvents

• Belden Infinity® Flexible Automation Cable

Belden Infinity is used when the application requires highly flexible cables offering exceptional life and performance.

- Reduced Cable Memory

Belden Infinity's unique design and neutralized cabling, results in cables that are relaxed, with almost no memory.

- Greater Flex Life

Belden Infinity cables offer superior flexibility and are able to handle the vigorous motions and high speeds encountered in automated equipment.

- Greater System Uptime

Belden Infinity cables combine specialized manufacturing techniques with precision copper stranding and rugged insulation and jacketing compounds to maximize flex life and reliability.

- No Talc Problems

Unlike the potentially harmful talc used in other cables, Belden's non-toxic, non-irritating slipper compound facilitates flexing and also complies with OSHA regulations. It's safer for employees and operators and is less likely to contaminate solder joints or mechanical compounds.

- CE Conformity

All Belden Infinity cables are CE marked per the Conformité Européenne low voltage directive, allowing trade of product in Europe.

- Custom Designs

Other designs available upon request.

• Armoring Capabilities

Belden offers both steel wire armor and interlocking (steel or aluminum) armor for extra protection against crushing and abrasion. Other solutions can be tailored to particular requirements.

To Specify Part Number:

1	2	3456
Overall Jacket Type	Armor Type	Core Trade Number

Overall Jacket Type

Code	Material
1	PVC
3	CPE
4	TPE
5	HDPE
6	Oil Res II
7	Haloarrest®

Armor Type

Code	Material
2	Aluminum Interlock
3	Steel Interlock
8	Continuous Corrugated Aluminum

Availability

Many of these are available off the shelf from distributors. If you have a new or unusual application or you cannot find an Industrial cable in this catalog section that meets your technical requirements, see our U.S. Master Catalog or contact technical support at +31-77-3875-414 or techsupport.venlo@belden.com.

Corresponding Literature

Product Bulletins

CB001: Belden's instrumentation & control capabilities

NP158: Blue Hose® cables

Shielding and Armoring

Overview

Innovative Leadership

The evolution of technology maintains steady demand for sophisticated cable shielding. Belden meets that demand with innovative shielding and shield effectiveness testing methods to supply you with high quality, dependable cable.

With the creation of trademarked shield designs and patented test methods, Belden has earned a reputation for innovation and leadership that is unequalled in the wire and cable industry. In addition, Belden offers the broadest line of shielded multi-conductor, coaxial and flat cable in the industry.

Several unique Belden innovations are utilized across a wide range of shielding applications:

- Beldfoil®**
 The first aluminum/polyester foil developed for use as a cable shield. Provides 100% shield coverage for optimum protection.
- Duofoil®**
 Consists of an aluminum-poly-aluminum laminate wrapped around the cable's dielectric core. Provides 100% physical coverage, and improves shield reliability and flex life.

Belden also utilizes a number of innovative techniques to apply shielding to multi-conductor and paired cables:

- "French Braid" Shields**
 Belden's patented "French Braid" shield is a double spiral (double serve shield) with the two spirals tied together by one weave.

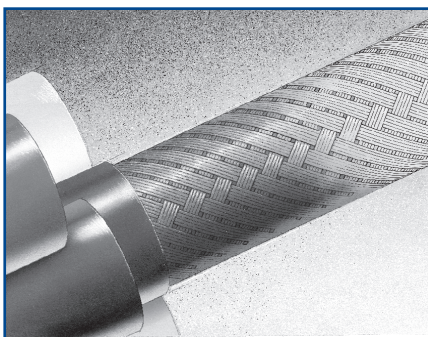

Belden's patented "French Braid" shield.

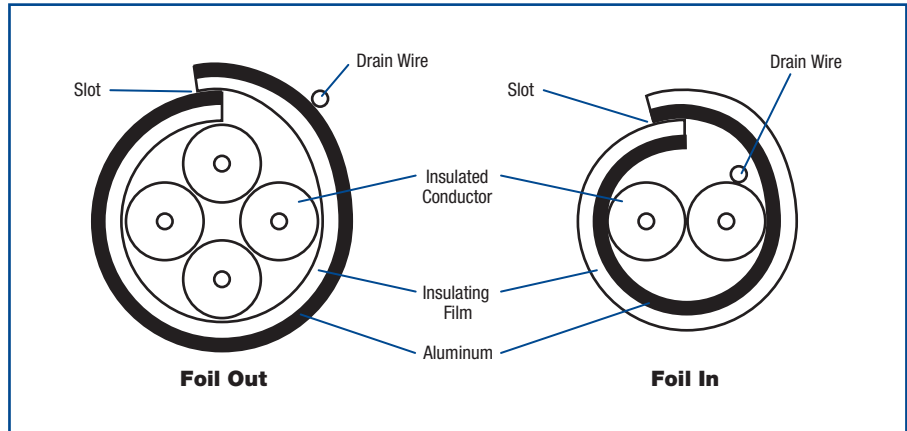

Figure 1: Foil shield configurations without shorting folds.

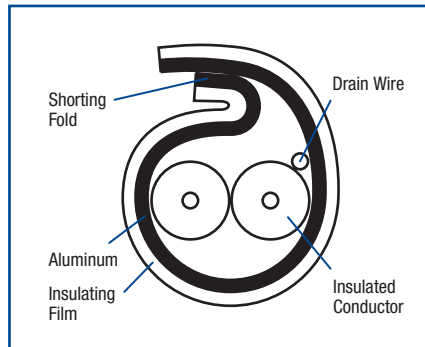

Figure 2: Foil shield configurations with shorting fold.

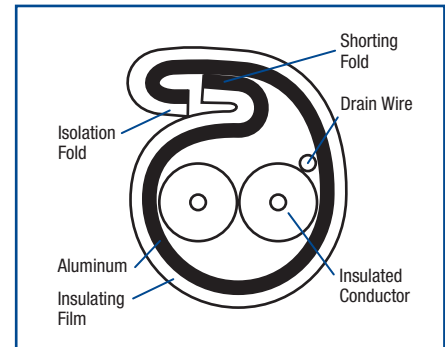

Figure 3: Foil shield with Z-fold reduces crosstalk in multi-pair applications.

- Shorting Fold**
 Belden uses a shorting fold technique to maintain metal-to-metal contact for improved high frequency performance. Without the shorting fold, a slot is created through which signals can leak and cause interference. (See figures 1 and 2 above.)

- Z-Fold®**
 Belden improves on the traditional shorting fold by employing a Z-Fold designed for use in multi-pair applications to reduce crosstalk. The Z-Fold (see figure 3) combines an isolation and a shorting fold. The shorting fold provides metal-to-metal contact while the isolation fold keeps shields from shorting to one another in multi-pair, individually shielded cables.

The use of either a shorting fold or a Z-Fold increases the foil shield's range of effectiveness to higher frequencies.